

Application Note: Using Witness Paper

SUMMARY

This application note describes how to add witness paper to freETarget.

- Witness Paper
- Paper Feed
- Switches
- Configuration
- Bill of Materials

INTRODUCTION

freETarget has the facility to add witness paper drive to the basic target. Witness paper ensures that there is always a complete target to put holes into and get a reliable shot location.

Using witness paper requires four parts:

- Witness Paper Holder and Guide
- Paper Feed
- Paper Feed Switches
- Software Configuration

Each of these topics are discussed separately

WITNESS PAPER and GUIDE

Witness paper comes in two widths; 90mm and 165mm. The 90mm width is typically used for rifle shooting, while the 165 is for pistol events. The choice is up to the user, but 90mm is more than sufficient to fill in the black portion of a pistol target.

An example of a paper holder is shown in Figure 1. The witness paper holder is wide enough to fit a 92mm paper roll. This provides a standard 90mm roll with 1mm of clearance on each side. In this example, the witness paper rolls under a round (5mm) bar that lines the paper up with the target. Because of this bar, the witness paper is on a free rolling mount that lets the roll adjust its position as the paper is used.



Figure 1: Witness Paper Holder

PAPER DRIVE

The paper drive in Figure 2, 3, and 4 is made from several components.

- Frame
 - Base
 - Left Pinch Roller Bearing
 - Right Pinch Roller Bearing
- Motor
- Coupling
- Drive Shaft
- Pinch Rollers
- Tear Bar

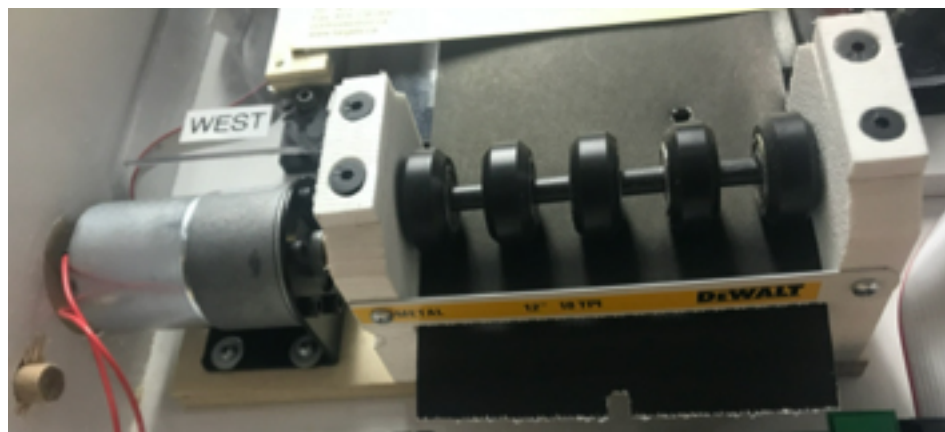

Figure 2: Paper Drive Assembly

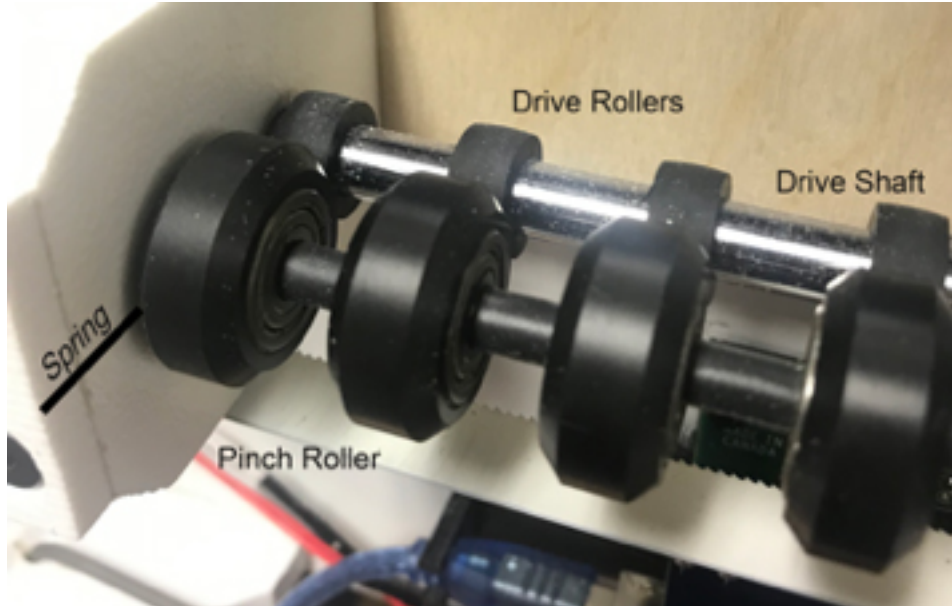

Figure 2A: Drive Rollers



Figure 3: Motor Coupling



Figure 4: Pinch Roller Bearings

Construction

In this example, the base is made from 1/4" plywood, and the pinch roller bearings from PVC plastic.

Construction begins by sizing out the base plate needed to hold the motor, left pinch roller bearing, paper, and right pinch roller bearing. In this example the base plate is 18cm x 5cm, Next the pinch roller bearings are cut from PVC plastic. PVC was chosen since it is naturally slippery and does not need any lubricant. In this example the bearings are 50mm x 65mm Begin by locating the motor and motor mount on one side of the base plate. Next, mark the place where the drive shaft touches the bearing plates. Drill the holes for the drive shaft as seen in Figure 3.

The drive rollers purchased from Amazon come with a 6 mm arbor. Drill or cut the arbor out leaving just the rubber wheel. Slide the rubber wheel onto the 8mm drive shaft, this will require some force, but it can be done. Test fit the motor, drive shaft, and drive rollers. Assemble the

pinch rollers onto the shaft and mark where they will need to be to fit against the drive shaft. Drill an oblong hold into both pinch roller bearings. Note that Figure 4 shows a slotted hole for the pinch rollers. This is done so that the pinch rollers can be pressed against the drive shaft when assembled.

Drill a hole through both pinch roller bearings for the spring to fit into.
Assemble the witness paper drive.

Testing

Cut a small length of witness paper and insert it into the drive. The slotted hole for the pinch rollers should be long enough that you can move the pinch roller away and slide in the paper. When the pinch rollers are in contact with the drive rollers the witness paper should not be able to be moved.

Apply power to the motor, does the witness paper move easily? You may find that the drive shaft binds in the mounting plates. If this happens, loosen the bolts holding the plates to the mount by ½ turn.

Wiring

A control to drive a witness paper roller is provided by the Motor Drive Pin. This pin provides a ground connection through a MOS-FET transistor.

The user has the option of turning on a DC motor for a period of time, or issuing pulses to a stepper motor controller. The number of pulses and the pulse duration is available from the setup page on the PC program. The duration of the motor control will be installation dependent and found by trial-and-error

A typical connection for a DC motor is shown in Figure 2.

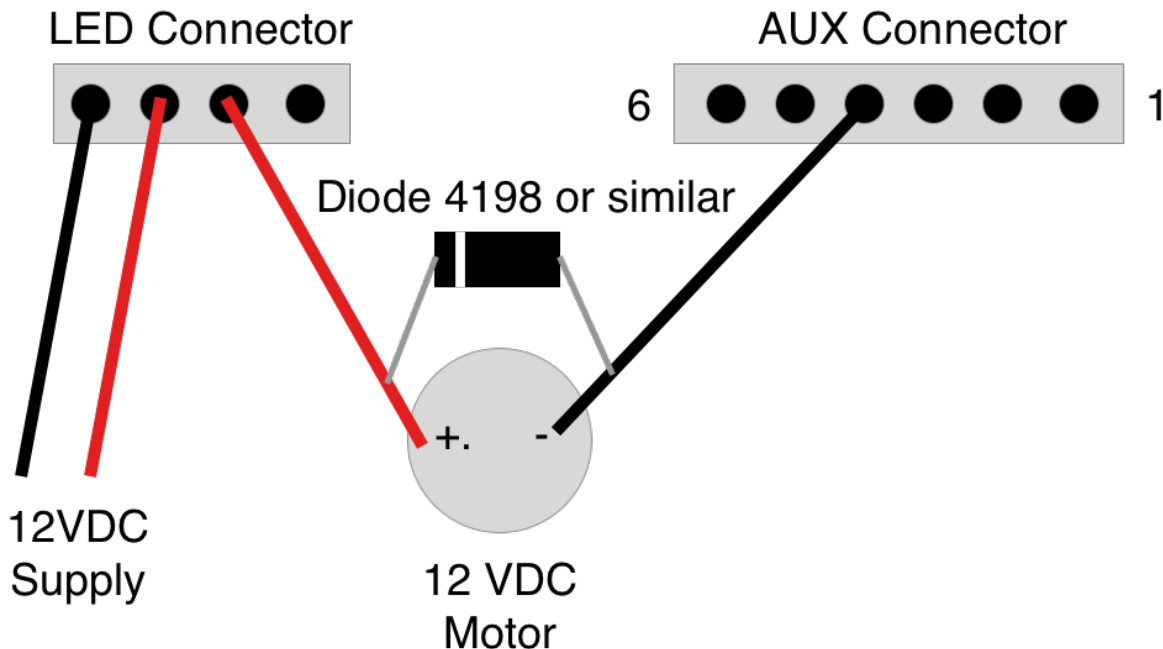

Figure 2: DC Motor Connection

IMPORTANT – Stepper Motor Control

The software provides the ability to pulse a stepper motor circuit for a given number of pulses and periods. The user must add a stepper motor interface such as A4988 available from Amazon to convert from pulses to motor phase drive

IMPORTANT – Feed Direction

The feed direction is determined by the motor polarity and the assembly of the parts. If the paper feed is backwards to the target, reverse the positive and negative motor leads.

PAPER FEED SWITCHES

The witness paper drive has provision for paper feed switches to advance the paper when loading. Figure 5 shows the switches, and Figure 6 shows the location on the DIP header. Figure 7 is a simple schematic of the switches and connection.

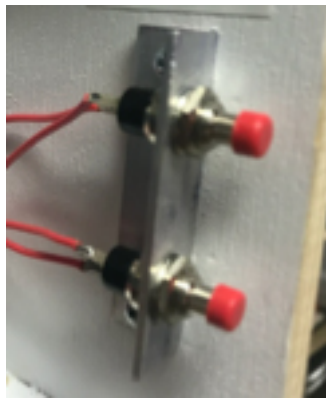

Figure 5: Paper Feed Switches



Figure 6: Wiring Connector – Uses DIP connection A and B

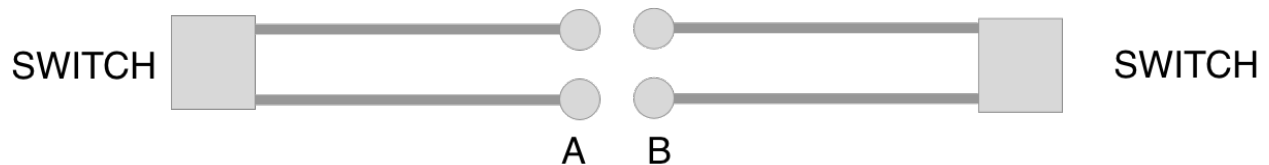

Figure 7: Switch Diagram

SOFTWARE CONFIGURATION

The witness paper needs the following configurations to be set as shown in Table 1

Table 1: Witness Paper Settings

Setting	Description	Typical Values
DC Motor		
PAPER_TIME	Duration motor is on to advance paper	500 ms (50)
Stepper Motor		
STEP_COUNT	Number of steps to issue to motor	25

STEP_TIME	Stepper motor ON time	5
Switches		
MFS	0-16 Upper Switch	1 – Paper Feed

BILL OF MATERIALS

Most of the materials on this list were obtained from Amazon simply for convenience.

Part	Description
Base	1/4" Plywood or similar
Left Roller Bracket	1/2" PVC or similar
Right Roller Bracket	1/2" PVC or similar
Pinch Roller Spring	5mm dia x 50mm long Ballpoint pen springs could be used instead
Fasteners	Various screws to fit
Part	From Amazon.com
12VDC Motor, 110 RPM	https://www.amazon.com/gp/product/B08D3SSG55/ref=ppx_yo_dt_b_asin_title_o09_s00?ie=UTF8&psc=1
Motor Mount	https://www.amazon.com/gp/product/B089W6DCGV/ref=ppx_yo_dt_b_asin_title_o09_s00?ie=UTF8&psc=1
6-8mm coupling	https://www.amazon.com/gp/product/B06X99P2XK/ref=ppx_yo_dt_b_asin_title_o09_s00?ie=UTF8&psc=1
Pinch Roller	https://www.amazon.com/gp/product/B088BXFT44/ref=ppx_yo_dt_b_asin_title_o05_s00?ie=UTF8&psc=1
Drive Roller	https://www.amazon.com/gp/product/B088BXFT44/ref=ppx_yo_dt_b_asin_title_o00_s00?ie=UTF8&psc=1
8mm x 100 mm Drive Shaft	https://www.amazon.com/gp/product/B082ZNXBWS/ref=ppx_yo_dt_b_asin_title_o00_s00?ie=UTF8&psc=1
5mm x 100mm Pinch Roller Shaft	https://www.amazon.com/gp/product/B082ZNXBWS/ref=ppx_yo_dt_b_asin_title_o00_s00?ie=UTF8&psc=1
Feed Switches, Push Button Normally Open	https://www.amazon.com/TwoDec-Colors-Momentary-Pre-soldered-PBS-110-X6C/dp/B07RPS2ZY3/ref=sr_1_5?ie=UTF8&qid=1628540916&sr=8-5&th=1

WHERE TO BUY WITNESS PAPER

Europe

Kreuger Targets. <https://targets.krueger-shops.eu>

North America

Orion Systems: [Paper Roll for Athena NC Models \(orionscoringsystem.com\)](http://www.orionscoringsystem.com)

Elite Scorer: [Electronic target, Electronic targets shooting, Target scoring system \(elitescorer.com\)](http://www.elitescorer.com)

Targets Canada: <http://www.targets.ca/products/targets-target-systems-and-accessories>

Make Your Own Witness Paper

For true Do-It-Yourself people, there are alternatives to commercially available witness paper

Black wallpaper – Available locally in paint supply stores

Black kraft paper – Example Amazon, https://www.amazon.com/RUSPEPA-Black-Kraft-Paper-Roll/dp/B07MNVSB16/ref=sr_1_1_sspa?crd=2SMOTR3V9LWLO&keywords=black+kraft+paper+roll&qid=1655243454&sprefix=black+Kraft%2Caps%2C80&sr=8-1-spons&psc=1&spLa=ZW5jcnlwdGVkUXVhbGlmaWVyPUFWOUM4TUFGWVAyNEgmZW5jcnlwdGVkSWQ9QTAzODYxODYzU09YMUg3RFBCUDhSJmVuY3J5cHRlZEFkSWQ9QTAwNTYwODYyQVVO RURKVDA1RU1UJndpZGdlE5hbWU9c3BfYXRmJmFjdGlvb11jbGlja1JIZGlyZWNOJmRvTm90TG9nQ2xpY2s9dHJ1ZQ==

Heat treated cash register paper – Use standard cash register paper and iron it to turn it black

Cut down witness paper – Cut 90mm witness paper in half using a band saw or similar tool